

# Vehicle Crossing Application

## Do I need to install a vehicle crossing?

You are required to install an appropriate vehicle crossing:

- To ensure that safe and appropriate vehicle access is provided and maintained by the property owner.
- To ensure that property owners protect footpaths, road shoulders, berm and underground utilities from damage due to the passage of vehicles
- To ensure that property owners prevent the flooding of their properties due to stormwater from the road and ensure that natural water flows along the road are maintained.
- To ensure that property owners prevent the flooding of the road due to stormwater from their properties.
- To prevent loose metal from rolling on to sealed roads and into the stormwater systems.
- If you are building a house or garage and there is an existing footpath outside your driveway.
- If required as a condition of a subdivision.

When the Council installs a footpath outside your driveway, you will be required to install a vehicle crossing if you have not done so already.

Remember a vehicle crossing adds value to your property!

*In all cases it is the owner's responsibility to provide and maintain and appropriate crossing.*

## What type of crossing must I install?

Crossings must be made of concrete or cobbles in urban areas and may also be chip sealed in rural areas. If the road is a metal road, the crossing can be metal also.

Gobi block crossings may be considered in place of cobbles where there is no footpath.

The details of the crossings are set out in the document titled VEHICLE CROSSING SPECIFICATION.

## What applications do I need and what fees apply?

By obtaining and filling out vehicle crossing application form from the nearest Thames-Coromandel District Council Office. The following fees are payable with the application:

Using a Contractor authorised to work without direct supervision      \$130.00 Incl GST

Using Contractor where supervision or inspection is required      \$225.00 Incl GST

Traffic safety issues **must** be resolved before you make your application. Our staff will be able to assist you in this regard.

**Who is permitted to construct a vehicle crossing?**

Any experienced person or contractor may construct a vehicle crossing.

Supervision or inspection of the work will be required to ensure that Council's objectives are not compromised. Council's supervision is not intended to guarantee the quality of work and does not in any way relieve the person doing the work of any of his obligations. Certain contractors have authority to construct vehicle crossings without such intensive supervision and we only carry out occasional checks on their work.

It will be advantageous for you to make use of these AUTHORISED CONTRACTORS. Our customer service staff will be able to provide you with a list of these contractors.

**Can any contractor be authorised to construct a vehicle crossing without supervision?**

Any suitably experienced contractor who is committed to working according to Council's specifications and has a satisfactory track record with Council may be authorised to construct vehicle crossings without supervision.

**Do I need to get permission from other authorities?**

If you are working on a State Highway in a rural area you must contact Transit New Zealand. Your work may also affect electricity or telephone cables, water mains or other services. You will need to be very careful about doing any excavation in the berm as damage to services can become very expensive or even dangerous. We would advise you to contact the appropriate utility authority. Your contractor may do this for you. The responsibilities in this regard finally rest with the property owner.

If you have reservations, we advise you to make use of an experienced contractor.

**What laws cover vehicle crossings?**

The Local Government Act and Council's Vehicle Crossing Bylaw enable Council to control activities in road reserve, set standards for vehicle crossings and if necessary, address problems caused by accesses.

Any person undertaking construction work must be aware of the framework of legislation covering traffic control and occupational safety.

**PLEASE DO NOT HESITATE TO ASK OUR CUSTOMER SERVICE STAFF IF YOU HAVE ANY OTHER QUESTIONS**

# Vehicle Crossing Specification

## 1. General

This specification provides for the installation of residential and rural vehicle crossings within the Thames Coromandel District Council district, spanning the footpath/berm from road edge to property boundary.

In the case of an owner-built crossing, reference to the contractor shall imply the owner of the section for the purposes of this specification.

No work shall be undertaken unless a consent from the Council has been issued.

Application forms are available at Council Offices.

In all cases finally, it is the owner's responsibility to provide and maintain an appropriate crossing.

## 2 Existing Services

2.1 The Contractor is responsible for the location of all other services and protection of such services.

2.2 The Contractor shall notify the owner or controlling authority of the proposed work and comply with any specific requirements for excavation that would affect their services.

2.3 In all cases finally the owner is accountable for any damage occurring to other services, building or structure, by this work. In event damage does occur, the Contractor shall immediately contact the owner or controlling authority and the Council.

2.4 The owner or controlling authority will make arrangements for necessary repairs for which the Contractor shall be liable for all costs incurred.

## 3 Inspections where supervision is required

The contractor shall provide one working day's notice to the local area office of the Council to ensure that the compacted subgrade layer is inspected and approved before the next phase is commenced.

Other inspections will be made when necessary.

Any work rejected or tests required by the Council shall be undertaken by the Contractor at the Contractor's expense.

## 4 Working Space

The Contractor shall confine his working space to the area of excavation unless specifically approved by the Council. The site shall not be a hazard to the public at any time, and the contractor shall comply with the Health and Safety in Employment Act 1992.

## 5 State Highways

Work on State Highway road reserve in a rural area will be subject to Transit New Zealand approvals. These must be obtained and forwarded to Council with the completed application form before any work commences.

## **6 Signs**

The Contractor is prohibited from erecting any signs other than traffic warning signs.

## **7 Clean Up**

On completion of the work the Contractor shall remove all plant, materials and any other items brought onto the site and leave it in a clean and tidy condition.

## **8 Gradients**

Gradient shall at no point exceed 1 in 8 or 12% within road reserve.

## **9 Construction Standard**

9.1 All vehicle crossings shall comply with the Code of Practice for Subdivision and Development, Section 3 (4.1 and 4.2). See copy attached

9.2 Gobi block crossings may be considered in place of cobbles where there is no footpath.

## **10 Geometric Standard**

10.1 A crossing shall not be located on a corner or within 6 metres of a tangent point of a corner of an intersecting road in an urban (50kph) area.

10.2 Council will not approve the installation of a crossing located at a point where horizontal or vertical sightlines are not adequate in a rural (60kph speed limit or higher) area.

10.3 Each property shall not have more than one vehicle entrance except with the written permission of the Council.

## **11 Mandatory Construction**

Council may require the owner of an existing crossing which is inadequately constructed or unsealed to construct the entrance to an approved standard:

- a. If loose metal from the entrance migrates on to the road or into any edge drain, culvert or stormwater system.
- b. If vehicle tracking is likely to damage underground services.
- c. If vehicles entering a section damage a public footpath.
- d. As a condition of a building consent.
- e. As a condition for a subdivision/land use consent.
- f. If deterioration of the formed road edge is occurring.

## **12 Stormwater Control**

The property owner shall ensure that the property runoff water is disposed of on the property, otherwise approved drainage facilities must be installed. Provision must be made to prevent road stormwater draining into the entrance and causing flooding of the section and/or surface water from private properties discharging on to the pavement.

## **13 Intrusions into Road**

The formal crossing shall not intrude into the trafficked carriageway and shall not obstruct water flow in the channel, culvert or side drains.

**14 Rural Standards**

Rural standards are specified in Drawing 600-217 and shall apply to vehicle crossings on rural roads.

See also Drawing 600.218 Rural Commercial Access.



CODE OF PRACTICE FOR  
SUBDIVISION AND DEVELOPMENT

Final Version  
Approved September 2003

SECTION 3 – STANDARD SPECIFICATIONS  
FOOTPATHS, CROSSINGS, BERMS

4.0 Construction

4.1 General

4.1.1 Dimensions

Footpaths, crossings and berms shall be constructed where shown on the drawings. Meanders in the horizontal geometry of the footpath shall be constructed generally at the locations shown on the drawings. Some tolerance in the exact positioning of the meanders will be allowed at the direction of the Engineer, in order to avoid existing service covers and street furniture.

The footpath width shall be 1.5m in all locations, Vehicle crossings shall be to the dimensions shown on the attached drawings or as shown on the construction plans.

4.1.2 Pavement Depth

The depth of the footpath pavement shall be as shown on the attached drawings and as detailed in the tables “Footpath Pavements” and “Vehicle Crossing Pavements” below.

Footpath Pavements

Footpath Type	Minimum Excavation Depth	Minimum Basecourse Depth	Surfacing
Asphaltic Concrete	120mm	100mm AP40	20mm AC7
Concrete (Developed Areas)	105mm	30mm AP20	100mm 20MPa Concrete
Concrete and sections without barrier kerb (Undeveloped areas) and sections without barrier kerb	170mm	50mm AP25	150mm 20Mpa Concrete

### Vehicle Crossing Pavements

Crossing Type	Minimum Excavation Depth	Minimum Subbase (AP65)	Minimum Basecourse	Surfacing
Residential (Urban)	155mm	30mm crusher finds	-	120 mm 20MPa Concrete
Commercial (Urban)	200mm	50mm crusher finds		150 mm 20MPa Concrete
Industrial (Urban)	250mm	50mm crusher finds		200 mm 20MPa Concrete + reinforce 665 mesh
Rural (Residential) Sealed road	250mm	150mm	100mm AP40 Grade 4 Chip Seal	
Rural (Commercial) Sealed Road	250mm	200mm	100mm AP40	2 wet coat Chip Seal
Rural (Industrial) Sealed Road		250mm	150mm AP40	2 wet coat Chip Seal
Rural Unsealed road		150mm	100mm AP40	50mm MAP20

The excavation depths shown on these tables are minimum depths. Should there be topsoil, or other unsuitable foundation material, at this depth the excavation shall be extended down to a sub grade with a CBR strength of at least 3. Alternatively, an approved geotextile shall be placed on the sub grade at the minimum excavation depth.

#### 4.1.3 Setting Out

The Contractor shall be responsible for the setting out of all footpath details both in horizontal and vertical geometry in accordance with the drawings and specifications and to the satisfaction of the Engineer. The checking, or any setting out of any line or level by the Engineer shall not in any way relieve the Contractor of his responsibilities under the contract.

#### 4.1.4 Stormwater Laterals

Every care shall be taken to ensure that property drains, and other stormwater pipes laid across the path are not broken or displaced and any damage in this respect must be completely made good.

	<p>CODE OF PRACTICE FOR SUBDIVISION AND DEVELOPMENT</p>	<p>Final Version Approved September 2003</p>
	<p>SECTION 3 – STANDARD SPECIFICATIONS FOOTPATHS, CROSSINGS, BERMS</p>	

#### 4.1.5 Surface Openings

All surface openings shall be adjusted in level so as to be generally flush with the finished footpath surfaces as set out below and the disturbed metal course re-compacted as specified elsewhere in this specification.

#### 4.1.6 Waterworks Surface Covers

The Contractor shall carry out adjustments in level of all Waterworks surface covers. Adjustments shall be made to surface covers, by firmly bedding and accurately positioning the covers on precast concrete frames or concrete bricks. Cast iron frames shall be set to protrude 2 mm above and lie parallel to the new surface of the path. Wood or earthenware bricks shall not be used to make small adjustments in surface level.

The Contractor shall rectify any subsidence during the maintenance period as soon as possible.

Existing valve boxes and fire hydrants shall be left clear of spoil and readily accessible at all times.

#### 4.1.7 Existing Telecom Manhole Tops

The Telecom Corporation of New Zealand will adjust Telecom manhole tops. The Contractor shall give adequate notice to Telecom of when they require this work to be carried out.

#### 4.1.8 Existing Sewer and Stormwater Manhole Tops

The Contractor shall adjust existing manhole tops when specified or directed to by the Engineer. This work shall meet all requirements of the TCDC Drainage Specifications

#### 4.1.9 New Telecom, Sewer and Stormwater Tops

These shall be installed to the correct level to suit the footpath.

#### 4.1.10 Other Existing Surface Openings

The Contractor shall adjust other surface openings such as vents, sewer gully traps, existing stormwater inspection openings, etc. within the footpath construction area.



	<p>CODE OF PRACTICE FOR SUBDIVISION AND DEVELOPMENT</p>	<p>Final Version Approved September 2003</p>
	<p>SECTION 3 – STANDARD SPECIFICATIONS FOOTPATHS, CROSSINGS, BERMS</p>	

#### 4.2 Sub grade Preparation

The footpath including all vehicle crossings, shall be constructed on solid sub grade compacted to a CBR of at least seven. The Contractor shall fill or excavate as necessary to bring the finished sub grade to the true level and crossfall. Should soft or otherwise unsuitable material be encountered extra excavation down to firm bearing may be required. This shall only be carried out at the direction of the Engineer. Before construction commences, the sub grade shall be rolled to produce a solid even surface to the satisfaction of the Engineer. No tolerance will be allowed which reduces the depth of the footpath construction.

ORIGINAL SIZE A4 DO NOT SCALE - IF IN DOUBT, ASK

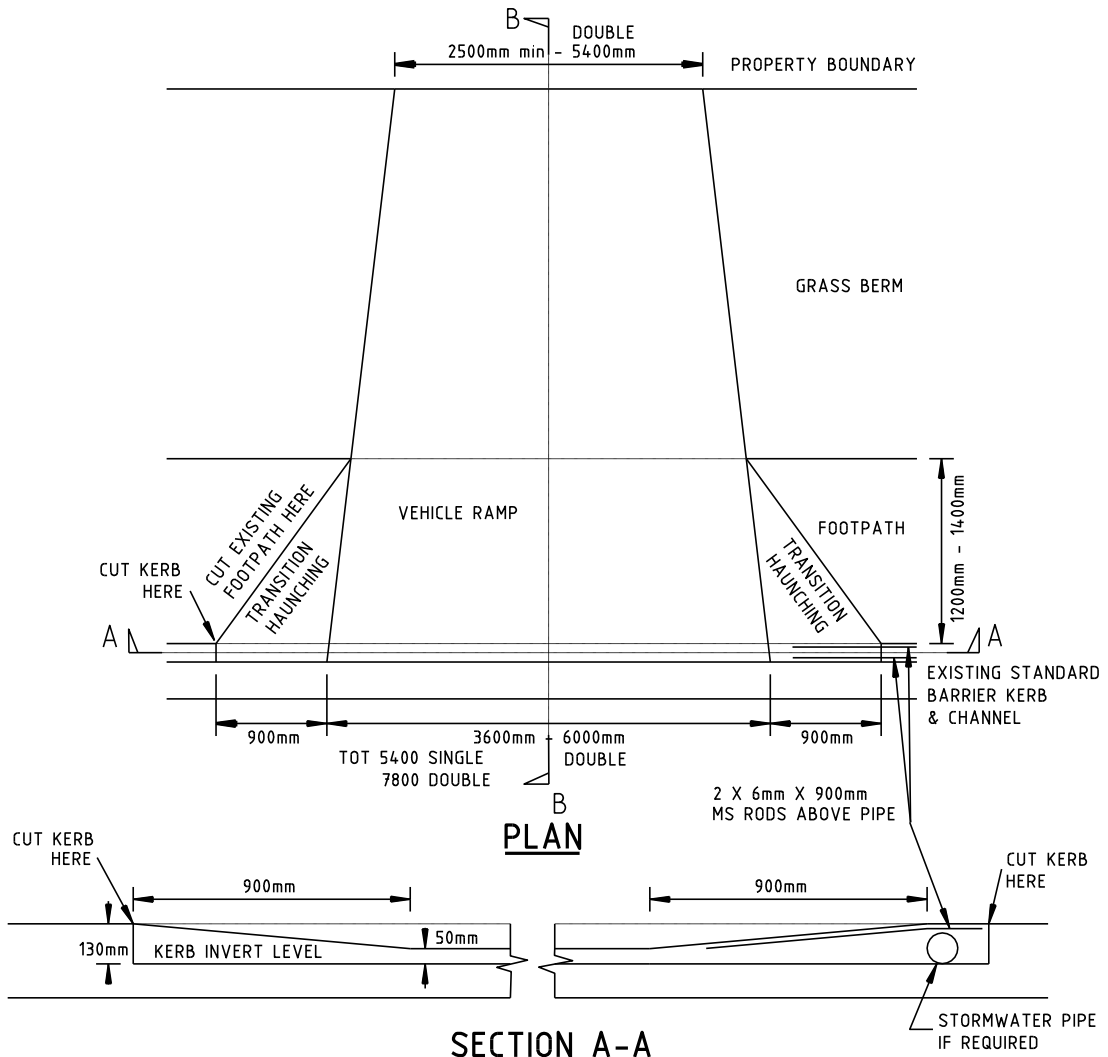

**SECTION A-A**

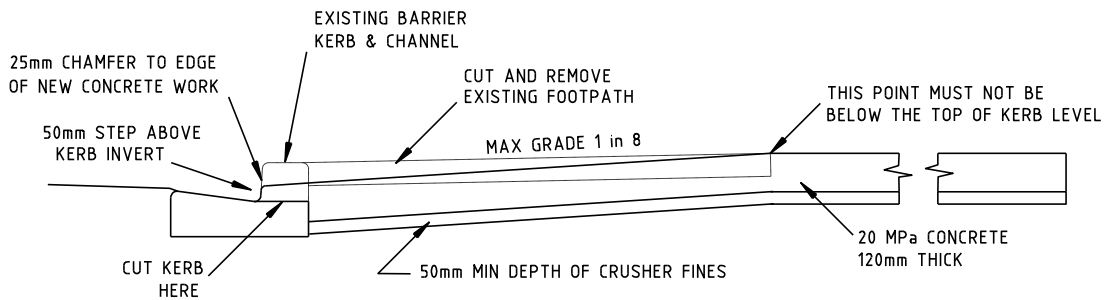

**SECTION B-B**

NOTE: FOR MOUNTABLE KERB BUTT NEW CONCRETE UP BEHIND KERB

CAD REF : \$FILES\$

SCALE  
**NTS**



SHEET TITLE  
**VEHICLE CROSSING  
STANDARD RESIDENTIAL  
FOOTPATH AT KERB**

PLAN No.  
**600-211A**  
Date Stamp  
01/08/2003  
ISSUE  
**A** Sheet No.

ORIGINAL SIZE A4 DO NOT SCALE - IF IN DOUBT, ASK

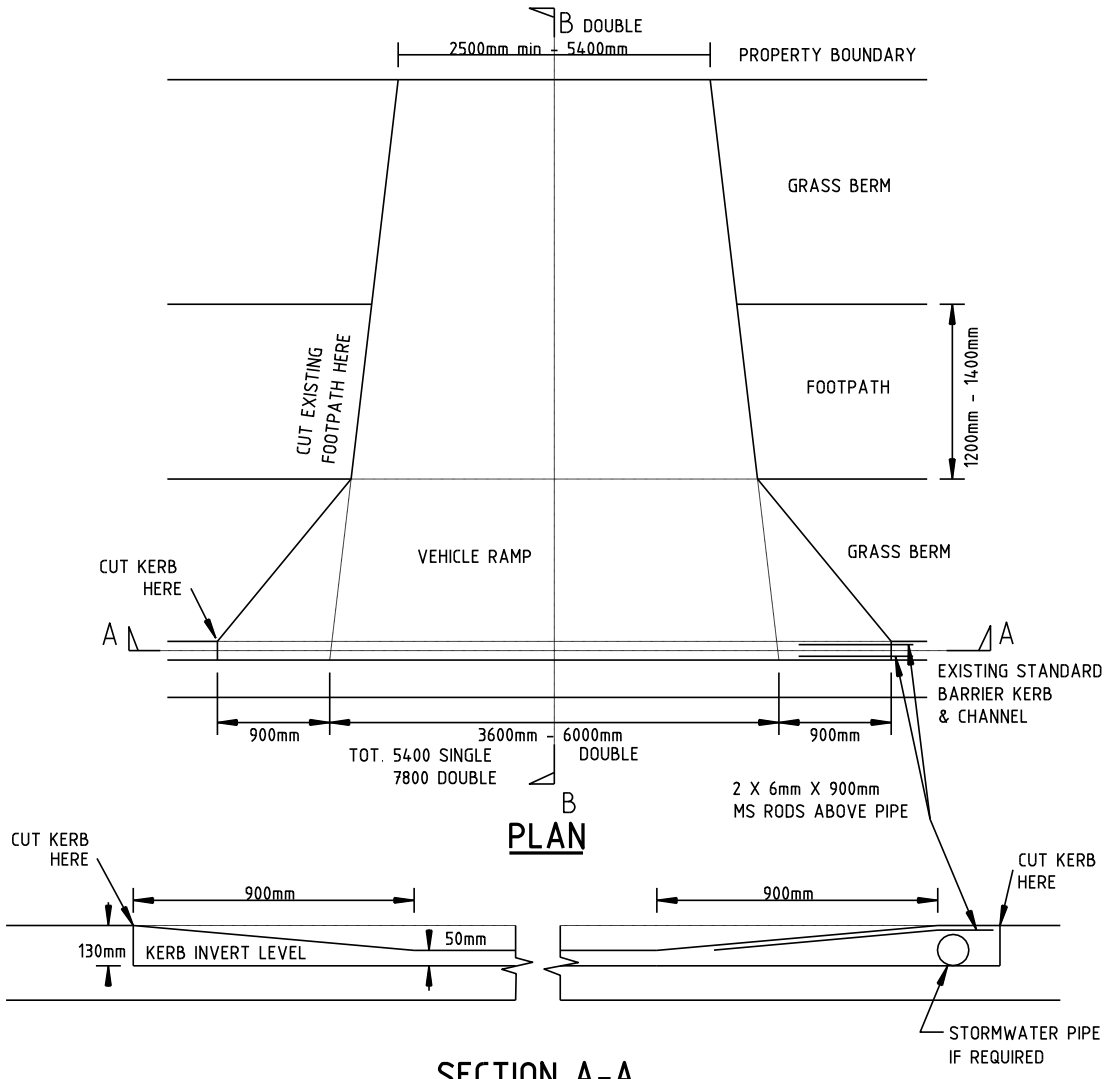

**SECTION A-A**

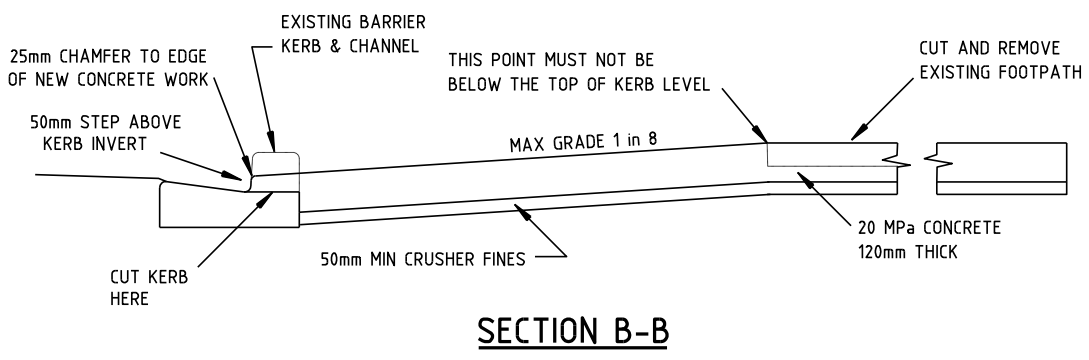

**SECTION B-B**

NOTE: FOR MOUNTABLE KERB BUTT NEW CONCRETE UP BEHIND KERB

CAD REF : \$FILE\$

SCALE <b>NTS</b>		SHEET TITLE <b>VEHICLE CROSSING STANDARD RESIDENTIAL FOOTPATH IN BERM</b>	PLAN No. <b>600-211B</b>	
			Date Stamp 01/08/2003	ISSUE A
			Sheet No. 1 of 1	

ORIGINAL SIZE A4 DO NOT SCALE - IF IN DOUBT, ASK

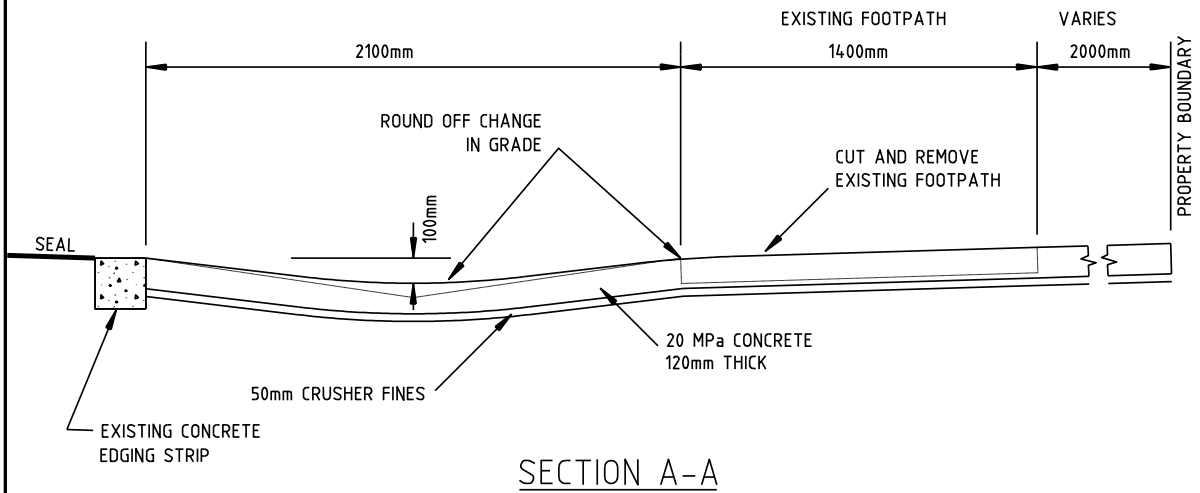
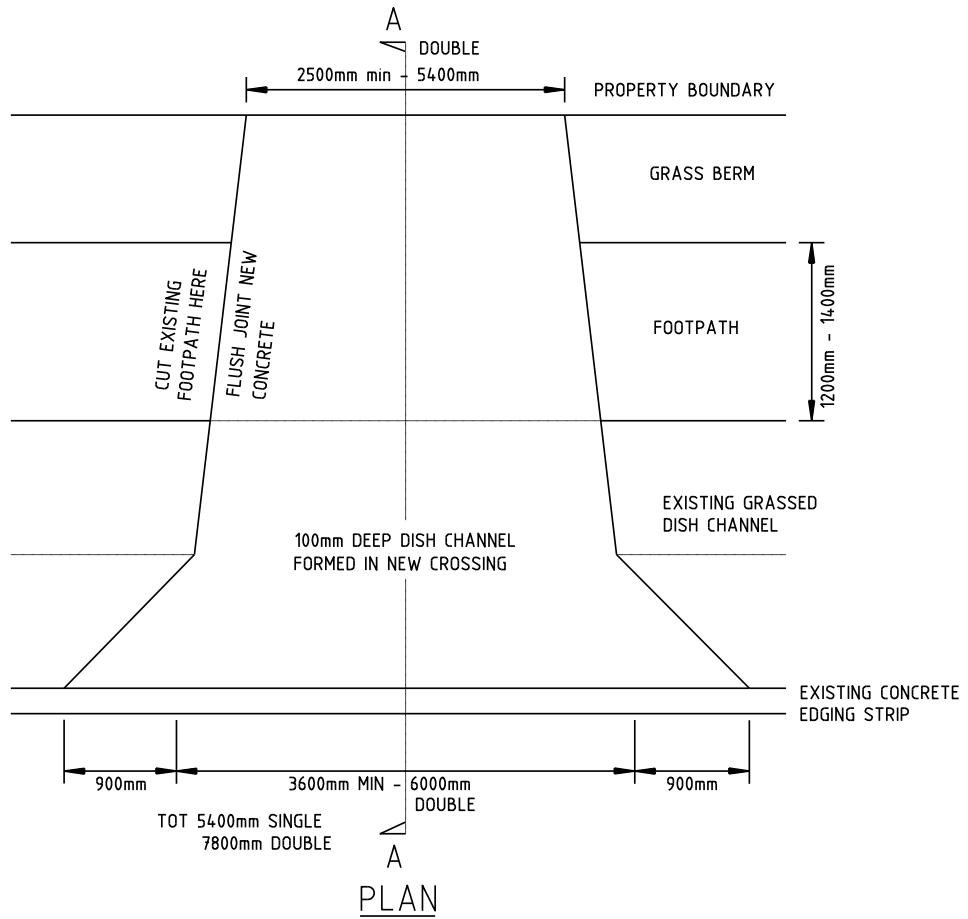

CAD REF : \$FILES\$

SCALE  
NTS



SHEET TITLE  
**VEHICLE CROSSING  
STANDARD RESIDENTIAL  
FOR DISHED BERM CHANNEL**

PLAN No. **600-211C**  
Date Stamp 01/08/2003  
ISSUE A Sheet No. 1 of 1

ORIGINAL SIZE A4 DO NOT SCALE - IF IN DOUBT, ASK

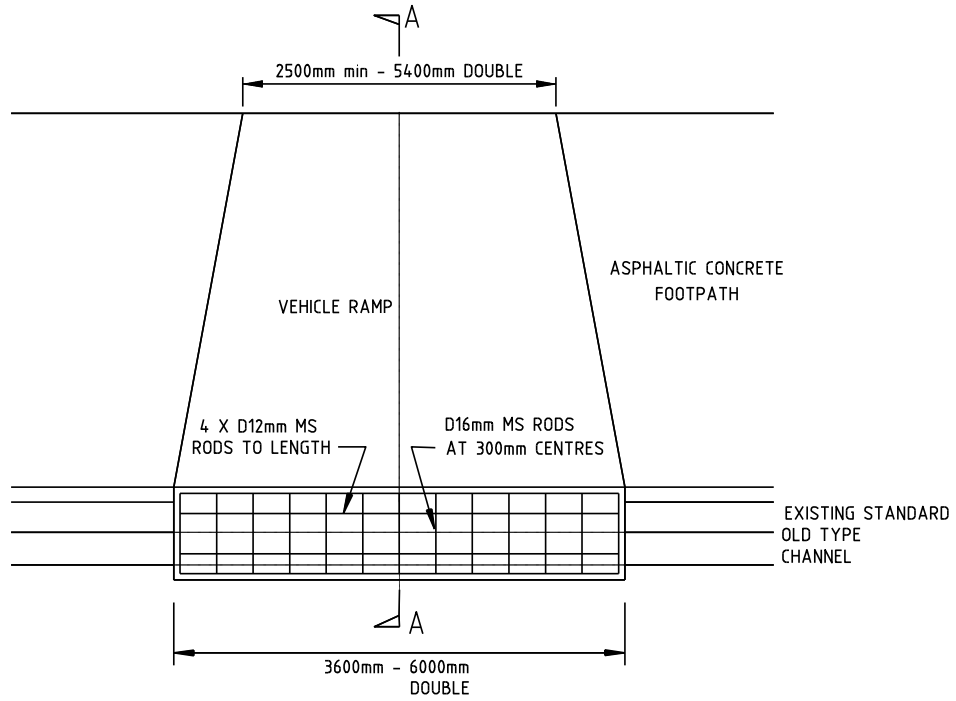

**PLAN**

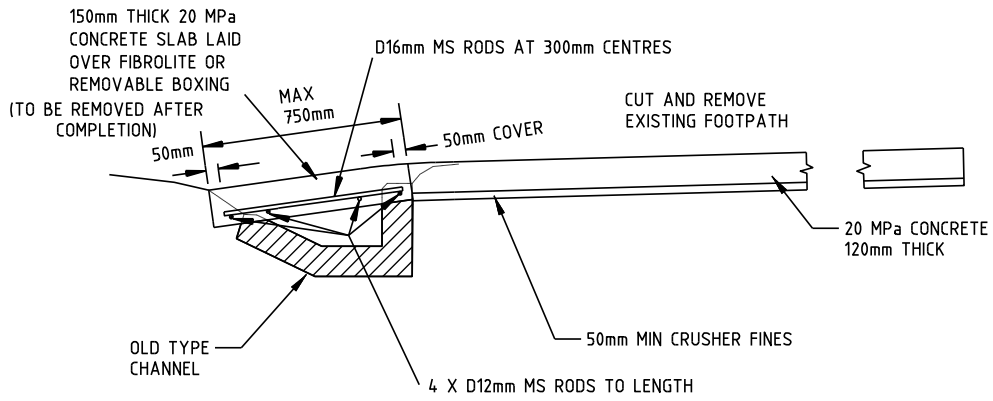

**SECTION A-A**

CAD REF : \$FILE\$

SCALE  
**NTS**



SHEET TITLE

**VEHICLE CROSSING  
STANDARD RESIDENTIAL  
FOR OLD TYPE CHANNEL**

PLAN No.

**600-211D**

Date Stamp 01/08/2003

ISSUE

A

Sheet No.

1 of 1

ORIGINAL SIZE A4 DO NOT SCALE - IF IN DOUBT, ASK

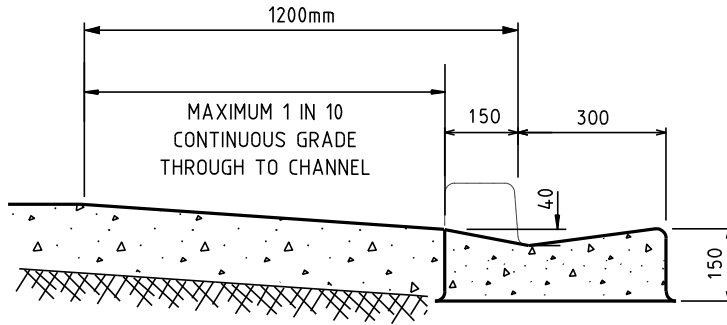

**SECTION A-A**

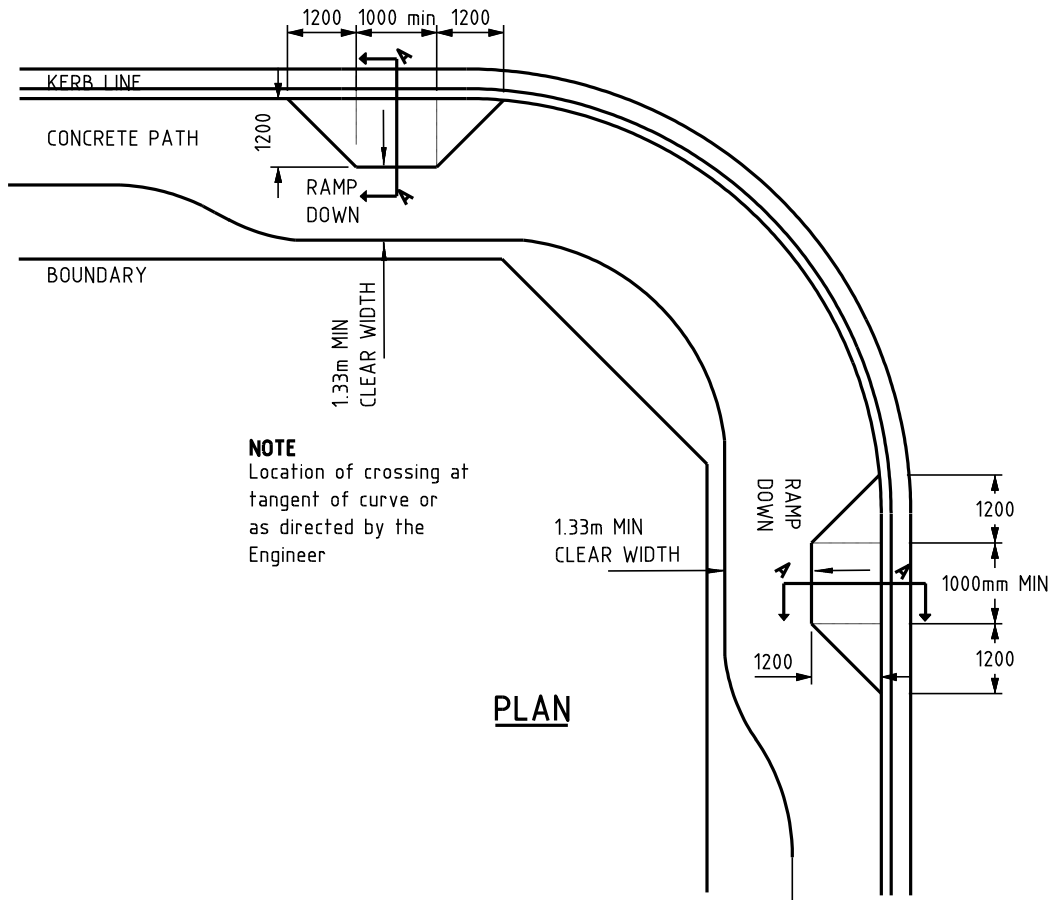

**PLAN**

**NOTE**  
Location of crossing at  
tangent of curve or  
as directed by the  
Engineer

CAD REF : \$FILE\$

SCALE

**NTS**



SHEET TITLE

**PEDESTRIAN CUTDOWN**

PLAN No.

**600-213**

Date Stamp

01/08/2003

ISSUE

**A**

Sheet No.

**1 of 1**

ORIGINAL SIZE A4 DO NOT SCALE - IF IN DOUBT, ASK

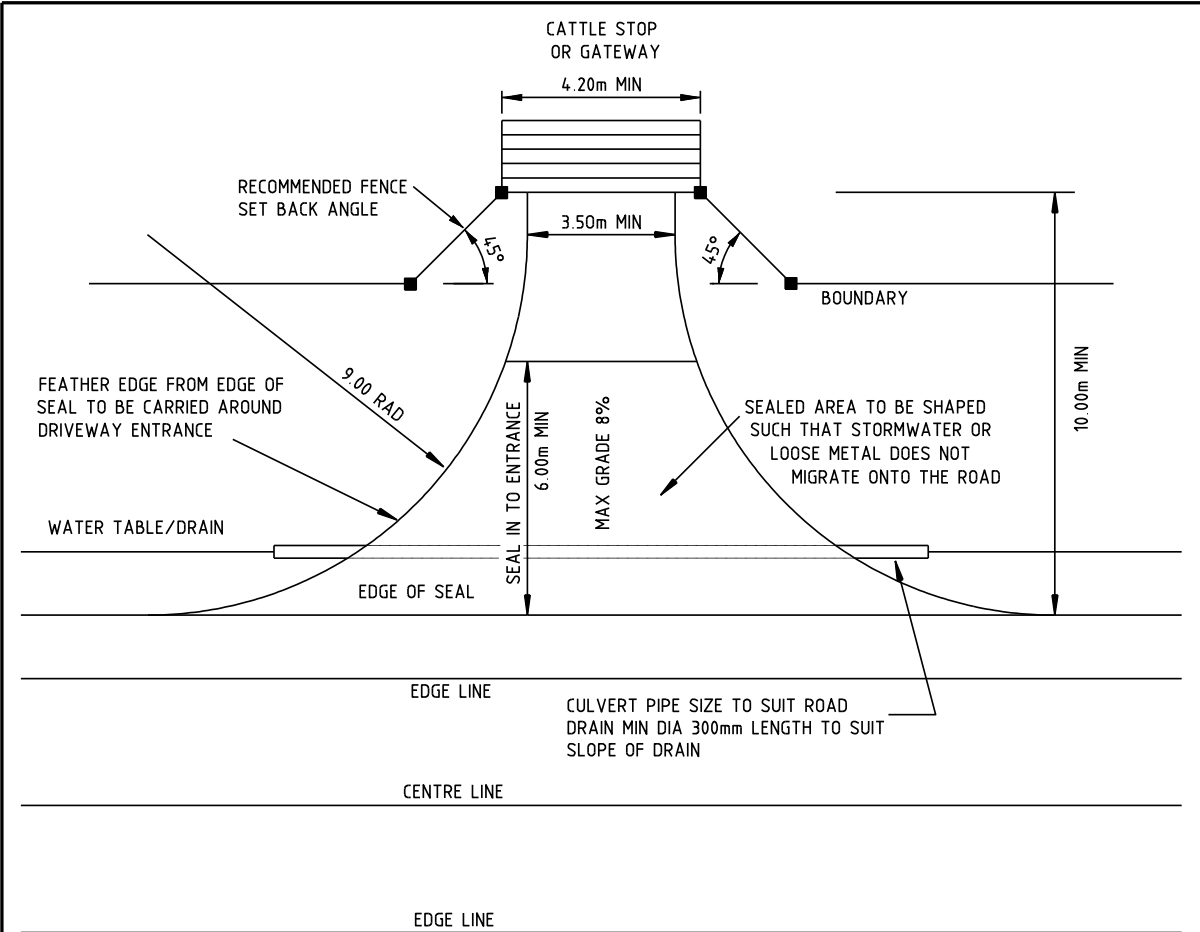

- NOTE:
- (1) WIDTH AT CATTLE STOP SHOULD BE INCREASED TO 5m FOR STATE HIGHWAYS TO MEET TRANSIT NEW ZEALAND REQUIREMENTS.
  - (2) THE WIDTH AT THE CATTLE STOP IS TO BE 5m FOR R.O.W. FRONTING COUNCIL ROADS TO PROVIDE PASSING WITHIN THE ENTRANCE OFF THE PUBLIC ROAD.
  - (3) THE MAXIMUM GRADIENT FROM THE EDGE OF THE SEAL TO THE PROPERTY BOUNDARY ON THE FIRST 6m IS TO BE 8 PERCENT.

#### MINIMUM FORMATION STANDARDS

The formation shall extend down to a suitable subgrade which shall be free of organic material. As a minimum requirement, the formation shall comprise of a 150 mm compacted layer of subbase (AP65) overlaid with a 100 millimeter compacted layer of base course (AP40). The top course shall be applied as follows:

- (a) Where the adjacent road formation is sealed, the entrance shall have a bound cohesive surface formation overlaid with a coat of chip seal, consisting of hot bitumen sprayed at a rate of 1.6 to 1.9 litres / square metre and grade 4 stone chip depending on surface conditions.
- (b) Where the adjacent road formation is metalled, the new entrance formation shall be overlaid with AP20 running course.

CAD REF : \$FILE\$

SCALE  
NTS



SHEET TITLE  
**VEHICLE CROSSING  
STANDARD FOR RURAL ROADS**

PLAN No. **600-217**  
Date Stamp 01/08/2003  
ISSUE A Sheet No. 1 of 1

ORIGINAL SIZE A4 DO NOT SCALE - IF IN DOUBT, ASK

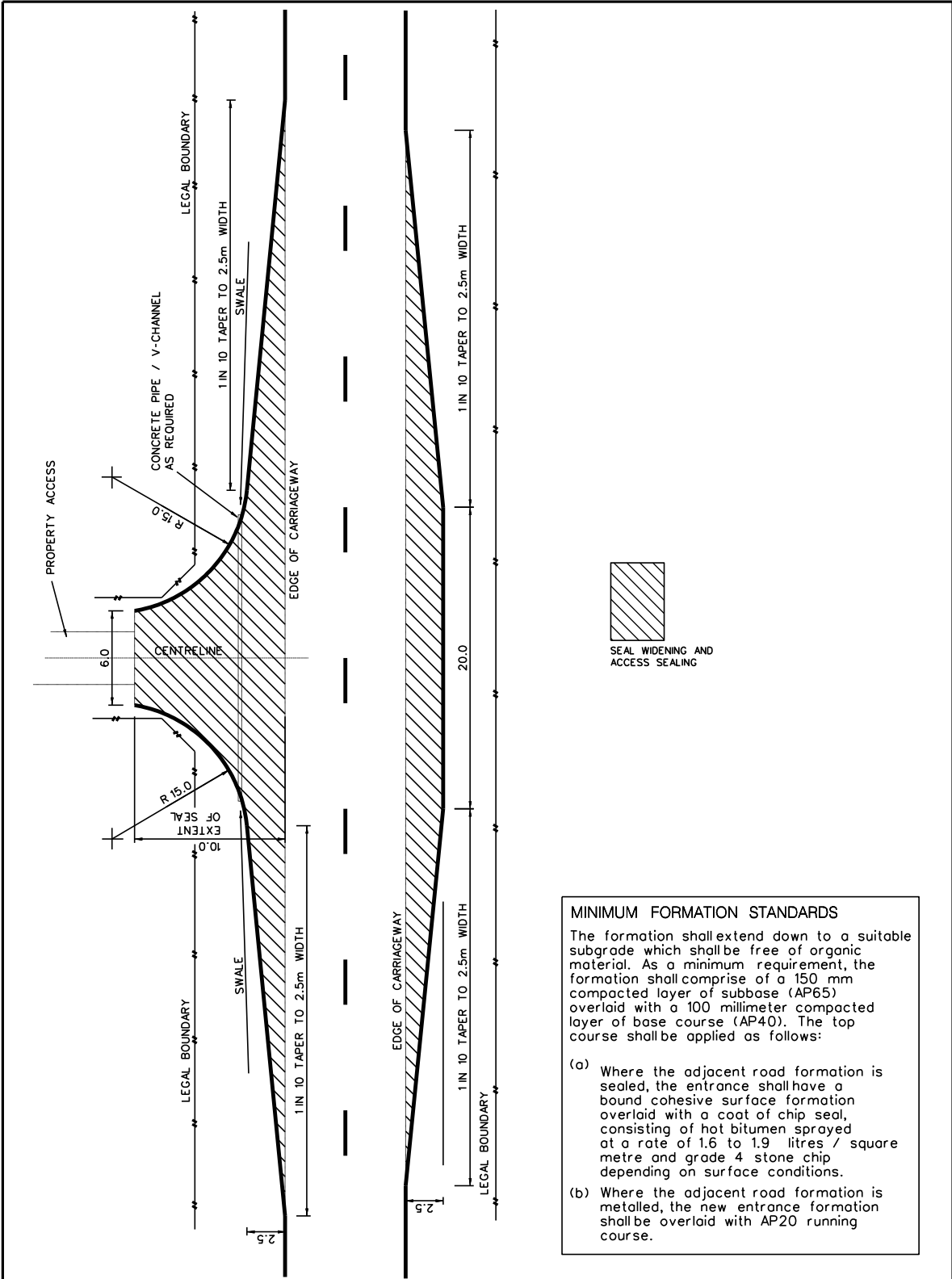

**MINIMUM FORMATION STANDARDS**

The formation shall extend down to a suitable subgrade which shall be free of organic material. As a minimum requirement, the formation shall comprise of a 150 mm compacted layer of subbase (AP65) overlaid with a 100 millimeter compacted layer of base course (AP40). The top course shall be applied as follows:

- (a) Where the adjacent road formation is sealed, the entrance shall have a bound cohesive surface formation overlaid with a coat of chip seal, consisting of hot bitumen sprayed at a rate of 1.6 to 1.9 litres / square metre and grade 4 stone chip depending on surface conditions.
- (b) Where the adjacent road formation is metalled, the new entrance formation shall be overlaid with AP20 running course.

CAD REF : \$FILE\$

SCALE  
**NTS**



SHEET TITLE  
**TYPICAL RURAL  
COMMERCIAL ACCESS**

PLAN No. **600-218**

Date Stamp 01/08/2003

ISSUE A Sheet No. 1 of 1



